



Title: Construction Challenges of 345kV Underground
Authors: Mr. Scott E. Newland, P.E., Burns & McDonnell
Mr. Michael E. Beehler, P.E., Burns & McDonnell

ABSTRACT

Burns & McDonnell is providing Program Management and detailed design for the Northeast Utilities (NUSCO) subsidiary Connecticut Light and Power (CL&P) on the Middletown/Norwalk Bulk Transmission Project, a \$1.2 Billion project scheduled for completion in December, 2009. The project includes 69 miles of new 345kV transmission line, of which approximately 24 miles will be solid dielectric 345kV underground cable, along with several new and modified substations. Although CL&P serves just more than 1.1 million customers in 149 towns and cities across Connecticut, the Middletown/Norwalk Project (MNP) is the largest transmission capital project in the country. NUSCO is responsible for the completion of 18.5 miles of the underground transmission portion of the project while the neighboring utility United Illuminated (UI) will handle approximately 5.5 miles of the underground transmission portion of the project. NU selected Burns & McDonnell based on their technical expertise, construction management experience, procurement team, project controls experience and overall staffing depth. Burns & McDonnell established an office near the project site and staffed it with nearly 25 professionals to assist NUSCO's Project Manager and Project Director with the complexities of the MNP. The underground transmission segment of this unprecedented program management effort will face multiple technical and construction challenges that have been and are being met by an outstanding team of engineers, lawyers, environmentalists, contractors and manufacturers. The scope of the MN 345kV underground transmission project includes permitting, land acquisition, splice vault design and installation, duct bank design and installation, cable pulling, splicing, terminations, final inspections and testing for a fee exceeding over \$40-50 million.



Figure 1. Project Plan

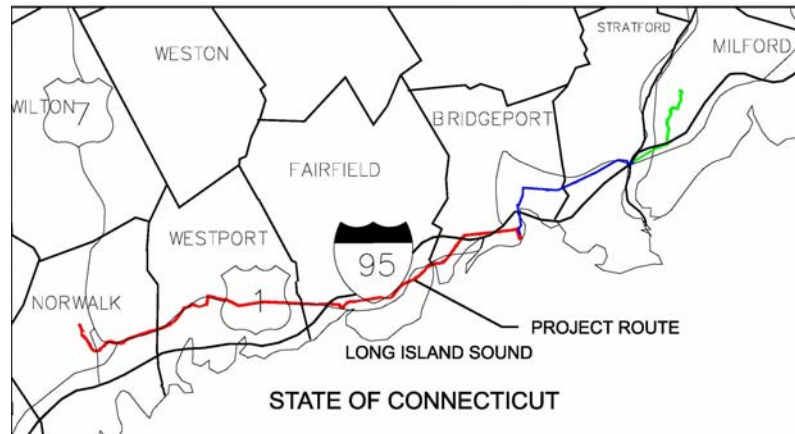

Route Description

The majority of the underground transmission alignment follows Connecticut State Route 1, one of the oldest highways in CT and one of the oldest roads in America. Route 1 is in Fairfield County, one of the most affluent counties in America. Each town's mayor or selectmen, engineer, attorney and director of public works is interested and involved in this project. The right to use the state right-of-way is governed by the Connecticut Department of Transportation (ConnDOT). A four feet (4') wide duct bank will be buried with a cover depth of at least 30" along the 4 lane divided and curbed highway as it traverses through heavy residential and small commercial areas. Decades worth of overhead and underground utilities and obstacles block the path of the duct bank system. Two adjacent 8' x 8' x 30' (inside dimensions) splice vaults will be located approximately every 1700 feet along the route. ConnDOT will not allow any splice vault structures under the paved surface of the road unless physical conditions preclude. As a result, many of the vaults will be located within adjacent landowner's parking lots. The off-street vault locations will require permanent and temporary easements. Most of the work performed on Route 1 will be performed at night from 6PM to 6AM and no steel plating will be allowed from the day after Thanksgiving to April 1st due to snow removal equipment. The project also crosses significant bodies of water including the Housatonic River, the Norwalk River (twice), the Pequonnock River, the Saugatuck River, South Port Harbor, Sasco Creek and Ash Creek.

Permitting

The permitting process includes acquiring permits from the Connecticut Siting Council, local municipalities, the ConnDOT and environmental agencies. The environmental agencies include the Office of Long Island Sound, Army Corps of Engineers, Inland Water Resources Division of the DEP, local wetlands and local coastal area management. Specific permits include local permits, noise waivers, traffic control, de-watering (federal & local), soil handling and street opening permits. The project team is acquiring a General Encroachment Agreement from the ConnDOT to establish the general construction and design constraints along state roads. Burns & McDonnell has hired a local sub-consultant to assist with field investigations and permitting. Burns & McDonnell and NUSCO started the permitting process with the Connecticut Siting Council (CSC) in mid-2003 and NUSCO hired Burns & McDonnell as program manager in mid-2004. The CSC issued an unanimous decision for the project on April 7, 2005 and construction will start on the duct bank system in June, 2006. Burns & McDonnell is responsible for the entire permitting process including presentations, application preparation, design coordination and construction management/coordination.



Land Acquisition

Land Acquisition is the responsibility of the program manager. Burns & McDonnell hired two local firms preferred by NUSCO to facilitate the process: a law firm, and a site acquisition/survey firm. The law firm prepares the easement agreements and leads the condemnation process and the acquisition/survey firm negotiates with the landowners. Easements are based on the square footage of land required and its assessed value and are paid for by NUSCO through the contractors. Burns & McDonnell reviews all easement documents prepared by the sub-consultants based on preliminary splice vault locations determined by working with the towns, landowners and ConnDOT. The program management team must demonstrate due diligence in negotiations before resorting to condemnation. Due diligence includes a minimum of 3 offers and a good faith effort to acquire the easement. The process of creating drawings, creating line lists and making offers to land owners can take 1-3 months while the condemnation hearings can take 6-8 months.

Field Investigations

Burns & McDonnell hired local engineering firms, geologists and scientists to assist with field investigations to determine construction constraints, geotechnical properties, location of existing utilities, location of hazardous and polluted material and a topographic and planimetric survey of the entire route. The geotechnical investigation includes approximately 175 borings spaced every 750' along the route. Thermal test engineers were on site with drill rigs to acquire thermal samples. The geotechnical investigation will assist with vault design issues, rock and water depth, soil classifications and thermal resistivity. Results of the geotechnical and thermal testing showed that 75% of 175 sites had water and rock was limited, although boulders and cobbles were encountered. The civil contractors were instructed to assume no rock in their bids and all rock excavation would be handled through allowances.

Subsurface Utility Engineering (SUE) has been performed along the underground route. SUE is the engineering process that identifies, characterizes, and maps underground utility facilities. It includes the three major activities of designating, locating, and data management. These activities, when combined with traditional record research, coordination with utility owners, and site surveys, provide utility information for use during Project development and design.

Designating services have been completed along the project. Designating is the engineering process of determining the presence and horizontal and vertical (if possible) location of underground utilities using geophysical prospecting techniques, including electromagnetic, magnetic, sonic, or other energy fields.

In addition to the designating services, locating services have been provided for the entire project route. Locating services include excavating test holes using vacuum excavation or comparable nondestructive equipment at critical points along a subsurface utility's path, exposing the utility and thereby allowing precise measurements of vertical and horizontal position. Approximately 800 vacuum excavations have been performed along the route.

We have also performed soil probing and sampling services in order to precharacterize soil and groundwater conditions and thus streamline the process of handling excavated subsurface soils and groundwater generated during the construction of a proposed underground duct bank and splice vault system along the entire underground transmission route. Excavation water effluent will be pumped into truck-mounted baker tanks, tested, treated & discharged to sanitary or storm sewers, depending on contaminants. The Connecticut Department of Environmental Protection (DEP) will set standards for contamination levels and direct the disposal. Soils may be contaminated, polluted or clean with some restrictions and must be exported to landfills. Prior to obtaining permanent easements, Burns & McDonnell hired an environmental firm to probe preliminary splice vault locations to sample soils so that the successful civil contractor would not have to test on site. Soil samples and other geotechnical information will allow the civil contractor to use the "Dig and Go" method, while installing 116 major splice vault structures and spending 8-14 days per dual splice vault location.



Splice vaults

Splice vault locations are determined by cable pulling calculations, cable reel lengths and manufacturer capabilities. The 8' x 8' x 30' (inside dimensions) vaults (see Figure 2) will be spaced approximately every 1700 feet (plus or minus 50-100 feet) along the 18.5 mile section(s) of line that NUSCO is constructing. Route 1 follows the coast closely through Southwest Connecticut and impacts many small plots of small commercial frontage with shared parking lots. NUSCO will acquire 6000 to 9000 sq. feet easements. Large excavations of at least 36' x 14' x 14' deep will be required for each vault. Tidal water tables will fluctuate between 3' and 15' below the surface.

Each splice vault is pre-cast, multi-sectioned and is watertight. The vaults are approximately 30,000 pounds per section and the design vehicle loading has been provided by ConnDOT. The splice vaults are grounded and contain end-bells for the electric and communication ducts that will be racked on a single side of the vault. Cable manufacturers specified the inside vault dimensions based on construction, maintenance and National Electric Safety Code clearances. The splice vaults will be supplied by regional pre-casters using custom structural designs and will have 10-12" thick walls. Burns & McDonnell has cost saving incentives built into the program management contract and is working with the Electric Power Research Institute (EPRI) to perform explosive testing inside the large pre-cast vaults to attempt to use one vault for dual circuits rather than two vaults per location. The dual circuit vault will have a concrete wall in the middle separating the two circuits, allowing repair of a damaged circuit with the other circuit energized.

Figure 2. Splice vault Cross Sections

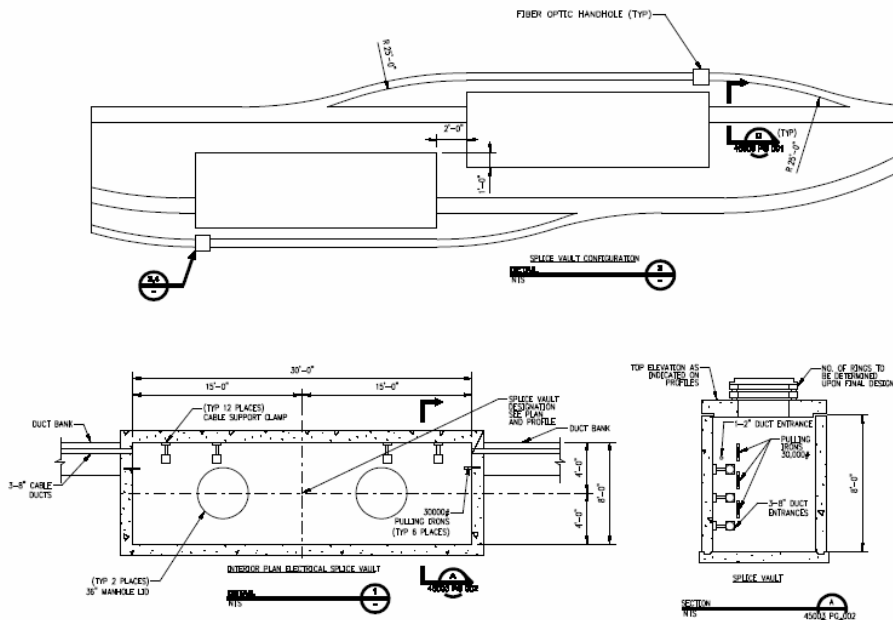

Duct Bank Installation

Burns & McDonnell expects the civil contractor(s) to achieve 100-150 ft of duct bank (see Figure 3) per day per crew and will run up to 10-12 vault and duck bank production crews at the peak of the construction period. In



addition, 2-3 supporting crews will be employed for utility relocation, repaving, and rock coring to break up the minimal rock that is expected without blasting, which the permits prohibit.

Figure 3. Cross Section of duct bank configuration

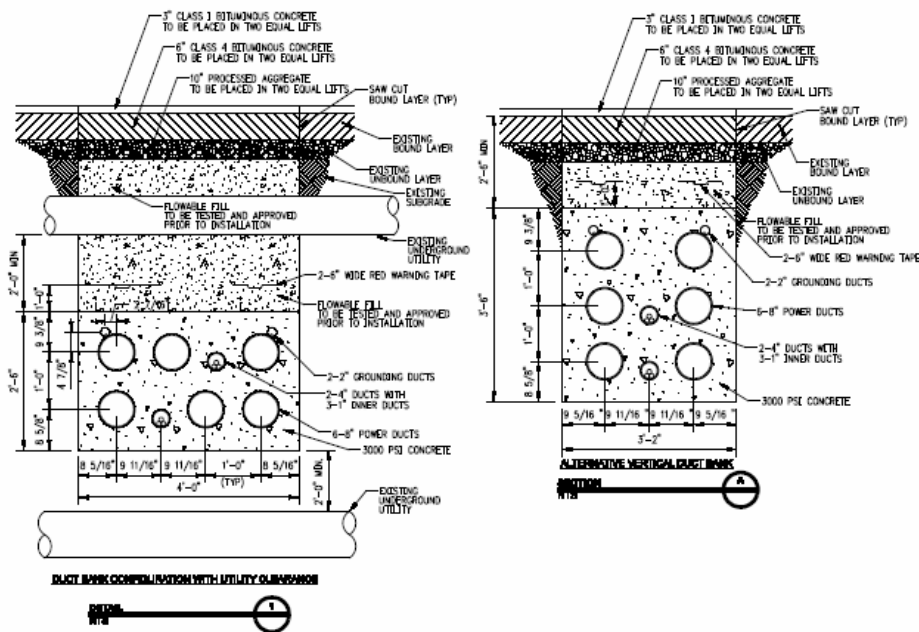

The duct bank size is at a minimum 4' x 4' and includes many horizontal and vertical curves to avoid trees, storm drains, sewers, foundations, etc., that increase pulling tensions and final cable lengths. The installation process includes saw cutting the road, excavating the trench, exporting the spoils, placing 20' lengths of 8" (id) PVC conduits in spacers, encasing with the ducts in 2500 psi concrete, backfilling the trench with a thermally tested flowable fill and laying a temporary patch. The concrete and flowable fill will undergo thermal testing and slump testing in the field for compliance with specifications. Fluidized Thermal Backfill (FTB) is a "diggable concrete" of 100-150 psi that allows thermal heat to escape from the energized conductors inside the duct bank, thereby minimizing any cable de-rating. After the FTB is placed at 3" below the surface, the civil contractor will apply a super pave asphalt concrete (AC) hot mix as temporary patch, returning later to perform the permanent pavement restoration by milling down the area 1.5" over two lanes of traffic and placing the final AC overlay final permanent pavement restoration. Asphalt plants close down mid December and re-open in late February in Connecticut and the only seasonal options may be from New Jersey at plants with a heated truck for hot mix as needed.

Burns & McDonnell safety personnel will make sure the civil contractor uses local police for traffic control. The cost is \$65-\$85 hour per man for a car with flashing lights and an officer to assist with traffic. Accidents happen daily on US I-95 and traffic is commonly diverted to Route 1. The emergency response plan will be initiated by the traffic control officer and the civil contractor will exit the road surface and open all lanes of Route 1 to traffic. All traffic control plans and signage are the responsibility of the civil contractor under the over sight of the program manager safety team that monitors and verifies adherence to the traffic control plan as allowed by the permitting agency.



Upon completion of the duct banks the civil contractor will “proof” the integrity of individual PVC ducts by a robotic video check, swabbing and mandreling. Swabbing involves running a ball of rags through ducts to look for tears on the cloth and mandrilling pulls an 18” wooden plug, sized one eighth of an inch smaller than the inside diameter of the duct, through the ducts to detect burrs, flaws, etc. that would damage the jacket of the cable. The civil contractor proofs the ducts with a swab and mandrel and then installs a “mule tape” to show the exact length of the individual duct bank with all the vertical and horizontal curves in place. Prior to cable pulling, the electrical contractor will re-swab and mandrel the ducts.

Horizontal Directional Drills/Jack and Bores/Duct Bridges

The MNP requires three dual 48” diameter horizontal direction drills of 700’ to 1800’ to depths of as much as fifty feet under the aforementioned rivers and will require the largest drilling contractors in the country. Each crossing has one drilled steel casing per circuit containing three 8” ducts, one 4” communication duct and one 2” grounding duct for each of the two circuits. The large 48” diameter helps to reduce the mutual heating of the loaded cables by spreading out each of the cables in a circuit. Thermally tested grout will be pumped into annular spaces of the 48” casings by calculating the theoretical volume of voids and then recording the actual volume installed under pressure.

Two railroad crossings require a horizontal augering of 100’-120’ long with 15’ of cover beneath the bottom of rail. The geotechnical considerations and the short distance of the crossing dictated the horizontal augering methodology and two 48” concrete casings will be augered into place due to thermal characteristics of concrete.

Two single span steel bridges will be used where ConnDOT refuses access to existing traffic bridges. The twelve foot wide steel bridges will carry the two duct banks and will be covered with fiberglass roofing to minimize the solar heating of the cables. Geotechnical and hydrological studies were performed to maintain clearances over the waterway for the 100 year flood event. Cross members of the steel bridge must be non-metallic due to electrical requirements. The duct bridges are a minimum of 15’ off the ConnDOT bridge right-of-way and will not allow pedestrian or vehicular traffic. Burns & McDonnell hired a local structural engineer to certify the bridge design and to satisfy ConnDOT (see Figure 4 and 5).



Figure 4. Cross section of bridge

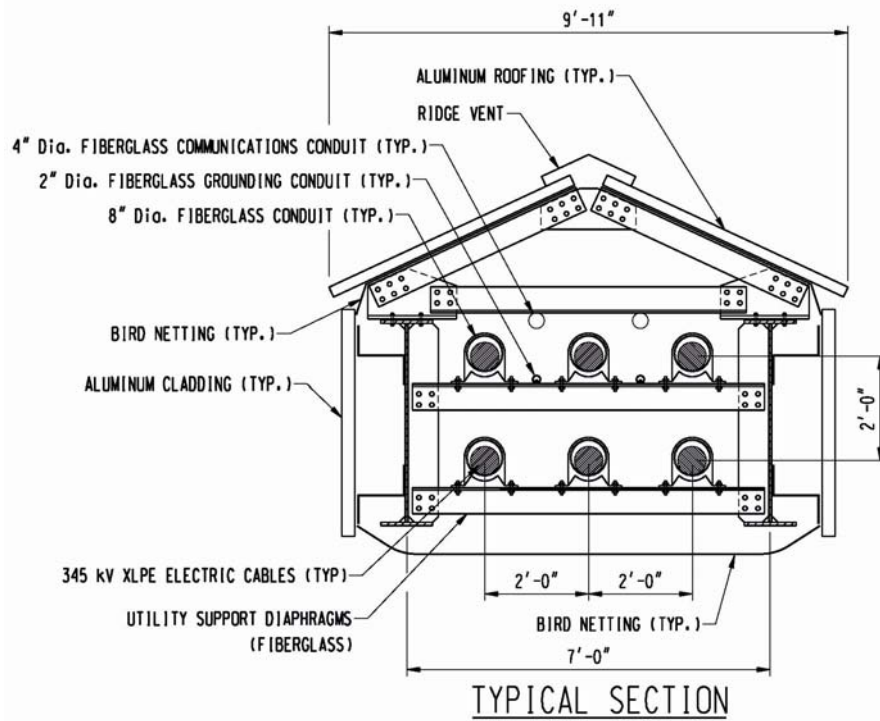
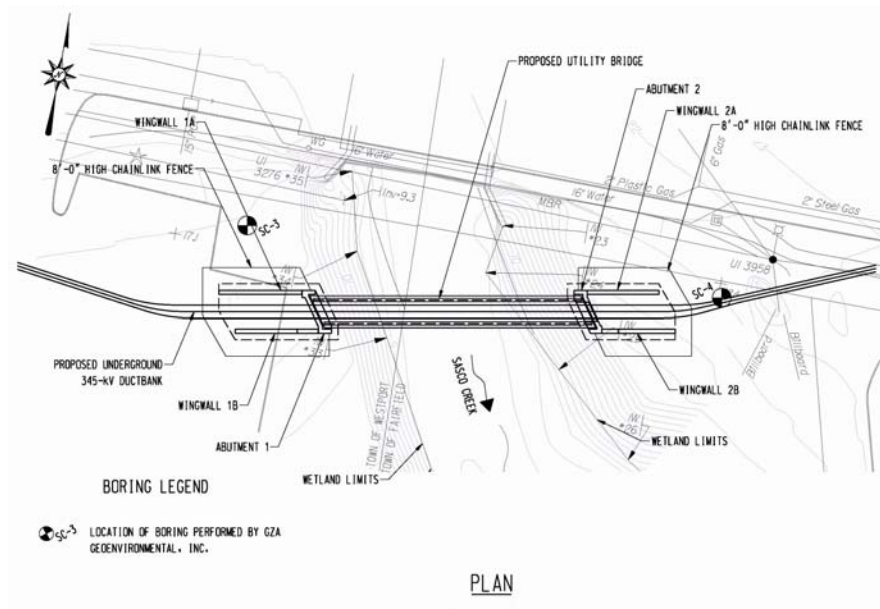

Figure 5. Plan view of bridge





Cable Pulling and Terminations

Burns & McDonnell will pre-qualify and select through competitive bidding one manufacturer for each circuit of the 345kV solid dielectric cable with a guaranteed two cable manufacturers on the project. The successful cable manufacturers will be hired under a furnish & install contract using one or more large US based electrical contractors. The cable for the MNP is a 3000 kcmil 345kV cross-linked poly-ethylene (XLPE) engineered, custom product jointly specified by NUSCO and UI. Three cables made of copper, epoxy, insulation and lead sheathing, and weighing 35 pounds per foot, makes a single circuit of 345kV that will carry up to 860MVA. Maximum allowable pulling tensions on the 3000 kcmil cable is approximately 22,000 pounds, but average tensions during construction will be approximately 15,000 pounds. Continuous pulls are important to the electrical contractor and major challenges occur if he is required to stop in the middle of a pull. Conduits are lubricated with a soap-like slurry product from 3M or others to lower the coefficient of friction from 0.3 (dry) to as low as 0.1 (optimum).

There are currently a couple of very short XLPE 345kV generator leads and no 345kV XLPE splices in the USA today. The MNP has 400 splices. The cable will be competitively bid to as many as five international cable providers at an anticipated cost of \$75-\$100 per foot and as much as \$300 per circuit with two circuits. The XLPE cable will be ordered in pre-cut lengths based on assumed splice vault locations. The total contract for the splices, terminations, and cable will be around \$80MM and will be purchased by Burns & McDonnell procurement staff. Current project schedules call for one to two pulls of cable per day per crew with each splice or termination requiring 4-5 days. 116 vaults each with 3 splices will require 1392 crew days to splice the 345kV cable.

Terminations occur in the substations only and risers sweep up out of the ground in a 90 degree low radius bend to a 7-8' high termination stand. The cable terminator is approximately eight feet tall and sets on top of the stand. The terminator mates to the aluminum conductor tail inside the substation. The electrical contractor performs final soak testing and jacket integrity testing under the supervision of the program manager's construction management and inspection team and then hands the finished system over to the owner for energization.

CONCLUSION

The underground 345kV segment of the Middletown/Norwalk Project will be completed in the summer of 2009. Progress to date has been good, but the construction challenges facing the Burns & McDonnell program management team will be monumental. The project will require efforts from all civil engineering disciplines and is technically one of a kind. Teamwork, technical competence and a great project owner have made this project one of the nation's most interesting transmission projects ever undertaken in the history of the power delivery industry.

¹ Burns & McDonnell Engineering Co., Inc., Transmission & Distribution Division, 9400 Ward Parkway, Kansas City, MO 64114; PH (816) 822-4322; FAX: (816) 822-3296; email: snewland@burnsmcd.com. Scott E. Newland graduated from the University of Nebraska-Lincoln in 1999 with a Bachelor of Science Degree in Civil Engineering. Mr. Newland is the Engineering Manager and Project Manager for the 345kV Underground Transmission portion of the Middletown to Norwalk Project. Mr. Newland has experience in managing underground transmission projects. He has been the lead engineer on several EPC and conventional engineering underground transmission lines. Over the course of his career, Mr. Newland has also developed an expertise in civil site design and foundation design. His responsibilities include steel design of standard and site specific equipment supports and design of several types of foundations, including spread footings, slabs on grade and drilled shafts. He has also been responsible for substation site development including design of earth excavation and embankment, underground duct bank design and oil containment systems. Scott and his wife Christina live in Overland Park, Kansas.

² Burns & McDonnell Engineering Co., Inc., Transmission & Distribution Division, 9400 Ward Parkway, Kansas City, MO 64114; PH (816) 822-3358; FAX: (816) 822-3296; email: mbeehle@burnsmcd.com. Michael E. Beehler graduated from the University of Arizona in 1981 with a Bachelor of Science Degree in Civil Engineering. He received the Master of Business Administration Degree from the University of Phoenix in 1984. Mike has held



various transmission engineering positions at the Tucson Electric Power Company and the Hawaiian Electric Company. He is currently the Director of Business Development of Burns & McDonnell Engineering Company, an international engineering consulting firm. He is a registered professional engineer in six states and is a Fellow in ASCE and a member of IEEE. Mike and his wife Dianne (Arizona '81) have four children and live in Leawood, Kansas.